



Authentic Recordings of **BIRD VOICES**

*From Cornell University's Library of
Natural Sounds. Produced by P. P. Kellogg and A. A. Allen*

SONGBIRDS OF AMERICA: *in color, sound, and story.* In this intriguing Bookalbum, high-fidelity recordings of the songs of 24 species of familiar birds taken in the wild are complemented by full-color photographs and useful information on their habits. *10-inch, vinylite record, 33 1/3 rpm, text, full-color photographs, spiral-bound.* \$4.95

AMERICAN BIRD SONGS, Volume One. The Robin, Catbird, Oriole, and Mockingbird are some of the familiar birds heard on this popular record, now released in a beautiful second issue. *The Biologist* termed the earlier album "The first great collection of our American bird songs" *12-inch, vinylite record, 33 1/3 rpm.* \$7.75

AMERICAN BIRD SONGS, Volume Two. The beauty and fidelity of the 51 bird voices heard on this disk are a tribute to the knowledge, patience, and skill of Drs. Kellogg and Allen. This 33 1/3 rpm record duplicates in every respect the earlier 78 rpm album. *12-inch, vinylite record, 33 1/3 rpm.* \$7.75

*Additional information on these and seven other records of
wildlife voices may be obtained by writing to:*

CORNELL UNIVERSITY RECORDS

*A division of Cornell University Press
124 Roberts Place, Ithaca, New York*

KODACHROME SLIDE SETS *to Match the Records*

The Laboratory of Ornithology at Cornell University is now offering Kodachrome slides of the species whose voices appear on the Cornell records. Slides from the famous collection of Dr. A. A. Allen are available for these albums: *American Bird Songs, Vol. I, 78 rpm, \$40.00; Vol. I, 33 1/3 rpm, \$35.00; Vol. II, 33 1/3 rpm, \$28.00. Songbirds of America, \$15.00.* Order directly from:

LABORATORY OF ORNITHOLOGY

Cornell University, 33 Sapsucker Woods Road, Ithaca, N. Y.

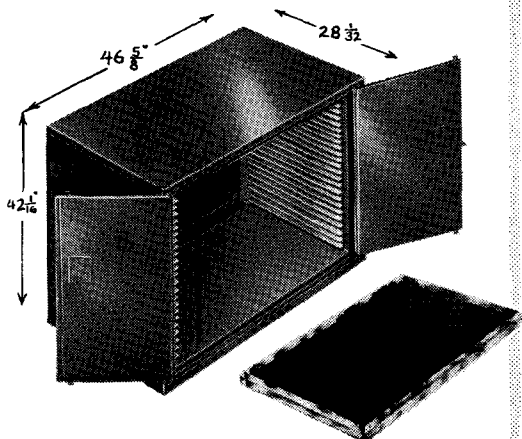

Skin Case #201 for Large Trays

**SKIN CASES
FOR
MAXIMUM
PROTECTION
CONVENIENCE
ECONOMY!**

Lane

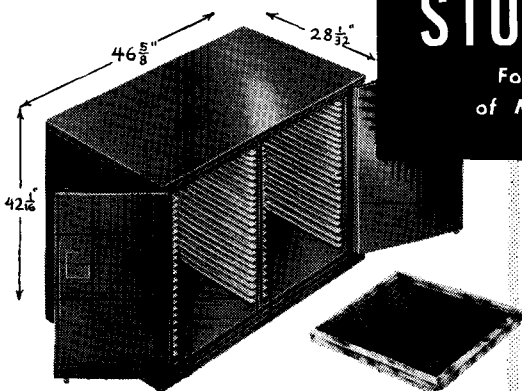

Skin Case #202 for Small Trays

ZOOLOGICAL AND ORNITHOLOGICAL

SPECIMEN STORAGE CASE

*For Protective Storage
of Mammal & Bird Skins*

- Locked "Live Rubber" Seal
- Sturdy double panel doors
- Locking mechanism secures both doors
- Tray guides permit maximum position of tray positions
- Fumigant Compartment
- Specimen Trays of aluminum and masonite — light weight — easy to handle.

FOR ILLUSTRATED BROCHURE WRITE

Institutional Division

CHAS J

Lane CORP

105 CHAMBERS STREET, NEW YORK 7, N. Y.

THE AUK

A Quarterly Journal of Ornithology

ORGAN OF THE AMERICAN ORNITHOLOGISTS' UNION

For publication in 'The Auk,' articles or notes must present material that is of significance to ornithologists and that has not been published elsewhere. All manuscripts should be typewritten, double spaced, with wide margins. Titles should be brief. Terminal bibliographies are used as a rule for long articles. Only works actually cited in the text are to be included in these bibliographies; works not so cited will be deleted by the editors. Where fewer than five references to literature are made, they may be inserted in parentheses in the text. References in manuscript for 'General Notes' should be in the text. Consult issues of 'The Auk' since January, 1949, for style of citation. Long articles should be summarized briefly. Footnotes, Roman numerals, and ruled tables are to be avoided. Acknowledgments belong in the text. Line drawings must be in India ink on white paper or drawing board; usually these should be planned for at least one-half reduction when printed. Thus, details and lettering must be correspondingly large. Legends must be brief. Photographs must be hard, glossy prints of good contrast. Common and scientific names of North American birds should follow the A.O.U. Check-List (Fifth Edition), except in taxonomic papers giving critical discussions and in justified special cases.

Proofs of all articles and notes will be sent to authors. Reprints from articles, 'General Notes,' and 'Correspondence' are to be paid for by the author. These must be ordered from the Editor on the blanks sent with the proof and must be returned with the proof. Printed covers can be furnished at additional cost.

All articles and notes submitted for publication and all books and publications intended for review should be sent to the Editor.

EUGENE EISENMANN, *American Museum of Natural History, Central Park West at 79th Street, New York 24, New York.*

All persons interested in ornithology are invited to join the American Ornithologists' Union. Application may be made to the Treasurer; dues for Members are \$4.00 per year. 'The Auk' is sent without charge to all classes of members not in arrears for dues.

Send changes of address, claims for undelivered or defective copies of 'The Auk,' and requests for information relative to advertising, subscriptions, back numbers of 'The Auk,' as well as for other publications of the Union, to the Treasurer.

CHARLES G. SIBLEY, *Fernow Hall, Cornell University, Ithaca, New York.*

OFFICERS OF THE AMERICAN ORNITHOLOGISTS' UNION

President: ERNST MAYR, Museum of Comparative Zoology, Harvard University, Cambridge 38, Massachusetts.

First Vice-President: AUSTIN L. RAND, Chicago Natural History Museum, Chicago 5, Illinois.

Second Vice-President: GEORGE H. LOWERY, JR., Museum of Zoology, Louisiana State University, Baton Rouge, Louisiana.

Editor: EUGENE EISENMANN, American Museum of Natural History, New York 24, New York.

Secretary: HAROLD F. MAYFIELD, River Road, RFD, Waterville, Ohio.

Treasurer: CHARLES G. SIBLEY, Fernow Hall, Cornell University, Ithaca, New York.

JOSEPH M. CADBURY

Member, Delaware Valley Ornithological Club

Says:

Audubon Field Notes contains a vast storehouse of information on the distribution and population dynamics of birds of the United States. The amateur and professional have both contributed to the overall picture of the changing patterns of our avifauna. From this magazine researchers assemble data to show population trends and to form the foundation for sound conservation policies. Each issue adds a new chapter to this dynamic and fascinating story.

AUDUBON FIELD NOTES

SUBSCRIBE TODAY!

Subscription for one year \$3.00
For two years 5.50
For three years 7.50
(Single copies of April Issue—Christmas Bird Count \$2.00)

1130 Fifth Avenue, New York 28, N. Y.

UNIVERSITY OF MINNESOTA SUMMER SESSION The Biology Session

At Lake Itasca Forestry and Biological Station

JUNE 16 TO JULY 19, 1958

Graduate and undergraduate field courses in ornithology, limnology, plant and animal ecology, mycology, entomology, agology, plant taxonomy, bryophytes, and pteridophytes. Teaching staff from the Universities of Minnesota, Wisconsin, Rutgers, Florida and California.

FOR BULLETIN, write to:

**DEAN, Summer Session, 836 Johnston Hall
UNIVERSITY OF MINNESOTA, Minneapolis 14, Minnesota**

BLEITZ WILDLIFE FOUNDATION have the following ALL NYLON mist nets available:

60 denier, 2 ply, 1½" mesh, 7' wide. #1—18' length \$2.00; #2—30' \$2.50; #3—42' \$3.00; #4—60' \$4.00

SPECIAL: #2X soft nylon 1½" mesh, 7' x 30' very full for maximum capture \$4.00
110 denier, 2 ply, 2¾" mesh, 7' wide. #5—18' length \$2.25; #2—30' \$2.50; #7—42' \$3.75; #8—60' \$5.50

210 denier, 2 ply, 4" mesh, 7' wide. #9—18' \$1.75; #10—30' \$2.25; #11—42' \$2.75; #12—60' \$3.75

#15—12' wide, 60' long 4" mesh special net for ducks, large shore birds, etc. \$12.50
We recommend #1 thru 4 and 2X for the catching of small birds. #5 thru 8 for medium size birds and #9 thru 12 for large birds.

Please include your Federal Bird Banding Permit number when ordering nets.

California orders please include 4% sales tax.

If money is included with order we will pay the postage.

BLEITZ WILDLIFE FOUNDATION

1001 North McCadden Place

Los Angeles 38, California

WANTED: young man with good knowledge of birds to be trained as an assistant in color photography lab processes. Some photographic knowledge helpful but not required. This is a permanent full time position in Los Angeles.

Apply to

MR. DON BLEITZ

1001 No. McCadden Place, Los Angeles 38, California