

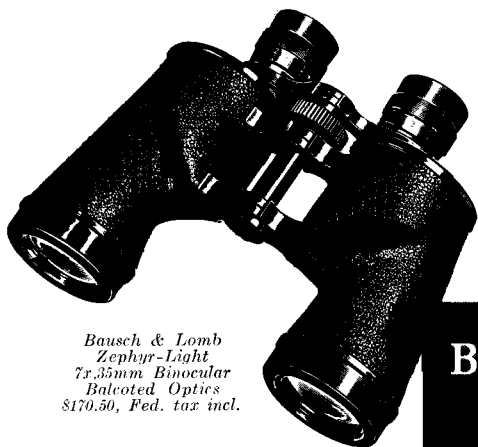

DR. ARTHUR A. ALLEN was the first Professor of Ornithology in a North American University, and Cornell is justly proud of his achievements. Over 10,000 students have learned about birds from him; his books and lectures, and color photographs of birds are outstanding in beauty and technical perfection. Dr. Allen is a long-time contributor to National Geographic Magazine, a contributing editor of Audubon Magazine, and Audubon Screen Tour lecturer. His newest book is "STALKING BIRDS WITH A COLOR CAMERA."

"A Good Binocular Makes Easy Identifications"

WRITES DR. ARTHUR A. ALLEN: "Since there are no blue or green pigments in the feathers of American birds, the observed color will depend on the angle of the light and the clarity of the image. A good binocular, highly corrected for color aberrations, makes easy identifications—poor binoculars may be misleading."



Bausch & Lomb
Zephyr-Light
7x35mm Binocular
Balcoated Optics
\$170.50, Fed. tax incl.

WRITE FOR FREE CATALOG. 32 pages of useful information you should know before you buy any binocular. Tells how to select a glass for your own use. Bausch & Lomb Optical Co., 12231 Lomb Park, Rochester 2, N. Y.

BAUSCH & LOMB

SINCE  1853

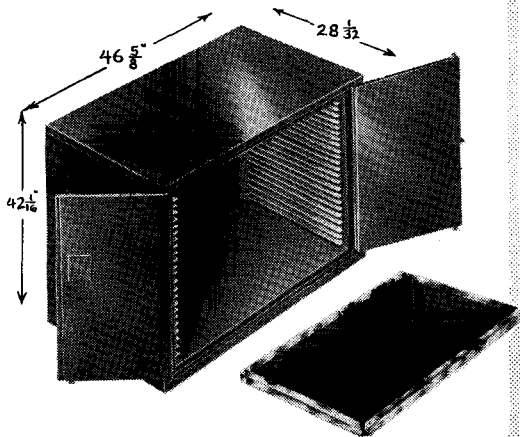

Skin Case #201 for Large Trays

**SKIN CASES
FOR
MAXIMUM
PROTECTION
CONVENIENCE
ECONOMY!**

Lane

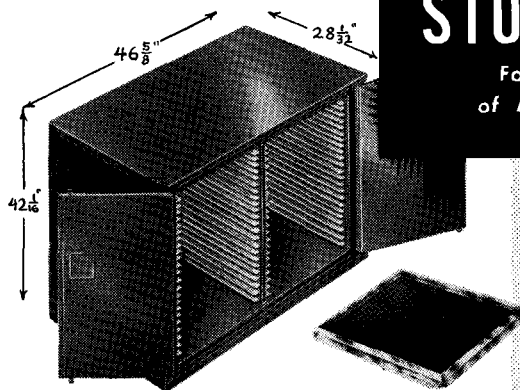

Skin Case #202 for Small Trays

ZOOLOGICAL AND ORNITHOLOGICAL

**SPECIMEN
STORAGE CASE**

*For Protective Storage
of Mammal & Bird Skins*

- Locked "Live Rubber" Seal
- Sturdy double panel doors
- Locking mechanism secures both doors
- Tray guides permit maximum position of tray positions
- Fumigant Compartment
- Specimen Trays of aluminum and masonite — light weight — easy to handle.

FOR ILLUSTRATED BROCHURE WRITE

Institutional Division

CHAS J

Lane CORP.

105 CHAMBERS STREET, NEW YORK 7, N. Y.

Some ornithologists have said

... "The study of live birds may be interesting, but why call it ornithology? Ornithology is a branch of science. Science is exact knowledge."

But, says Aretas A. Saunders, author of *The Lives of Wild Birds*, "the complete characters of any bird are not to be found merely in its dead body. The geographical range of a species, the migration route it travels, the habitat in which it lives, and the character and location of its nest are all admitted parts of ornithology, and depend on the instincts of the live bird. Our study of dead birds has laid the foundation for that of live ones. The science of ornithology here in America is not nearly complete, but only just begun."

THE LIVES OF WILD BIRDS

by **Aretas A. Saunders**

Illustrated with line drawings by Dominick D'Ostilio

● An expert tells how wild birds live, what to look for in studying them, and how to learn more about them—taking up such subjects as their migration routes, habitat, nesting cycle, courtship, nest building, egg laying, incubation, and care of the young . . . thorough data on identification by color and markings, size, shape, habit and posture, songs and calls . . . how they behave, what they eat, and where their nests can be found. In addition, the author has included a detailed discussion of the ecology of birds and a final chapter that is a stirring plea for conservation.

Bibliography; index. \$3.50

Your library should also contain Aretas A. Saunders' widely praised

A GUIDE TO BIRD SONGS

● The most complete and comprehensive volume on bird songs ever published, this book features Mr. Saunders' own practical system of "musical shorthand". Included are land birds and selected species of water and game birds, with their songs and calls set down in clear diagrams that assure easy identification.

Fully indexed, with more than 200 diagrams by the author. \$3

"An absolute necessity . . . by far the best book in the bird song field."—Richard Pough, *American Museum of Natural History*.

"I've used Saunders' system for years, and it has been invaluable for making notes in the field."—E. S. Thomas, *Curator of Natural History, Ohio State Museum*.

Send Coupon Today for Approval Copies of Both Books



DOUBLEDAY & COMPANY, Inc., Dept A Garden City, New York

Please send me, for 10 days FREE examination

..... copies of THE LIVES OF WILD BIRDS @ \$3.50 each

..... copies of A GUIDE TO BIRD SONGS @ \$3 each

Within 10 days, I will return the books and owe nothing or keep them and remit the full purchase price, plus postage.

NAME

ADDRESS

CITY ZONE STATE

SAVE! Check here if you prefer to enclose payment with this coupon, in which case we will prepay all shipping costs. Same return privilege; refund guaranteed.

THE AUK

A Quarterly Journal of Ornithology

ORGAN OF THE AMERICAN ORNITHOLOGISTS' UNION

For publication in 'The Auk,' articles or notes must present material that is of significance to ornithologists and that has not been published elsewhere. All manuscripts should be typewritten, double spaced, with wide margins. Titles should be brief. Terminal bibliographies are used as a rule for long articles. Only works actually cited in the text are to be included in these bibliographies; works not so cited will be deleted by the editors. Where fewer than five references to literature are made, they may be inserted in parentheses in the text. References in manuscript for 'General Notes' should be in the text. Consult issues of 'The Auk' since January 1949, for style of citation. Long articles should be summarized briefly. Footnotes, Roman numerals, and ruled tables are to be avoided. Acknowledgments belong in the text. Line drawings must be in India ink on white paper or drawing board; usually these should be planned for at least one-half reduction when printed. Thus, details and lettering must be correspondingly large. Legends must be brief. Photographs must be hard, glossy prints of good contrast. Common and scientific names of North American birds should follow the A.O.U. Check-List and supplements except in taxonomic papers giving critical discussions.

Proofs of all articles and notes will be sent to authors. Reprints from articles, 'General Notes,' and 'Correspondence' are to be paid for by the author. These must be ordered from the Editor on the blanks sent with the proof and must be returned with the proof. Printed covers can be furnished at additional cost.

All articles and notes submitted for publication and all books and publications intended for review should be sent to the Editor.

ROBERT W. STORER, *Museum of Zoology, University of Michigan, Ann Arbor, Michigan.*

All persons interested in ornithology are invited to join the American Ornithologists' Union. Application may be made to the Treasurer; dues for Associates are \$4.00 per year. 'The Auk' is sent without charge to all classes of members not in arrears for dues.

Send changes of address, claims for undelivered or defective copies of 'The Auk,' and requests for information relative to advertising, subscriptions, back numbers of 'The Auk,' as well as for other publications of the Union, to the Treasurer.

CHARLES G. SIBLEY, *Fernow Hall, Cornell University, Ithaca, New York.*

OFFICERS OF THE AMERICAN ORNITHOLOGISTS' UNION

President: ALDEN H. MILLER, University of California, Museum of Vertebrate Zoology, Berkeley 4, California.

First Vice-President: LUDLOW GRISCOM, Harvard University, Museum of Comparative Zoology, Cambridge 38, Massachusetts.

Second Vice-President: ERNST MAYR, Harvard University, Museum of Comparative Zoology, Cambridge 38, Massachusetts.

Editor: ROBERT W. STORER, University of Michigan, Museum of Zoology, Ann Arbor, Michigan.

Secretary: HAROLD F. MAYFIELD, 2557 Portsmouth Avenue, Toledo 13, Ohio.

Treasurer: CHARLES G. SIBLEY, Cornell University, Fernow Hall, Ithaca, New York.

BOB ALLEN

Research Associate,
National Audubon Society

Says

In its detailed accuracy, geographic coverage and number of contributors *Audubon Field Notes* is a unique demonstration of a steadily growing interest in bird watching in this country. It is also evidence of a wholesome maturity among those who study birds for a hobby. Not only does each issue represent many happy, healthy hours afield (which is, in itself, important), but the data thus placed on record comprise a reference source of great potential value.

Subscription: One year \$3.00 Two years \$5.50 Three years \$7.50

Separate copies of April issue—Christmas Bird Count—\$2.00

NATIONAL AUDUBON SOCIETY

1130 Fifth Avenue, New York 28, N. Y.

WAREHOUSE DISTRIBUTORS OF ORNITHOLOGICAL COLLECTING SUPPLIES

TOOLS—All Available Makes

SHOT—We stock hard to get # 12's, and all other sizes of chilled shot

WADS—10, 12, 16, 20 and 410 Gauge Wads for Shotshells

POWDER—We actually store in our own magazines all the numbers of
DuPONT and HERCULES Rifle and Shotgun Powders—
Both SMOKELESS and BLACK

PRIMERS—All Sizes

Write Us About Your Collector's Loading Problems

**We Are the Largest Exclusive Distributors of Ammunition Loading
Material in the World**

PRECISION TOOL & GUN CO.

303-305 E. Upland Road, Ithaca, N. Y.

TEN YEAR INDEXES TO "THE AUK"

at \$3.00 each; Check-list Supplements at \$.25 each.

Price list of available back issues of "The Auk"
will be sent upon request.

CHARLES G. SIBLEY, Treasurer

Fernow Hall, Cornell University, Ithaca, N. Y.